

Ballestra Multitube Falling Film Reactor SULPHONEXT

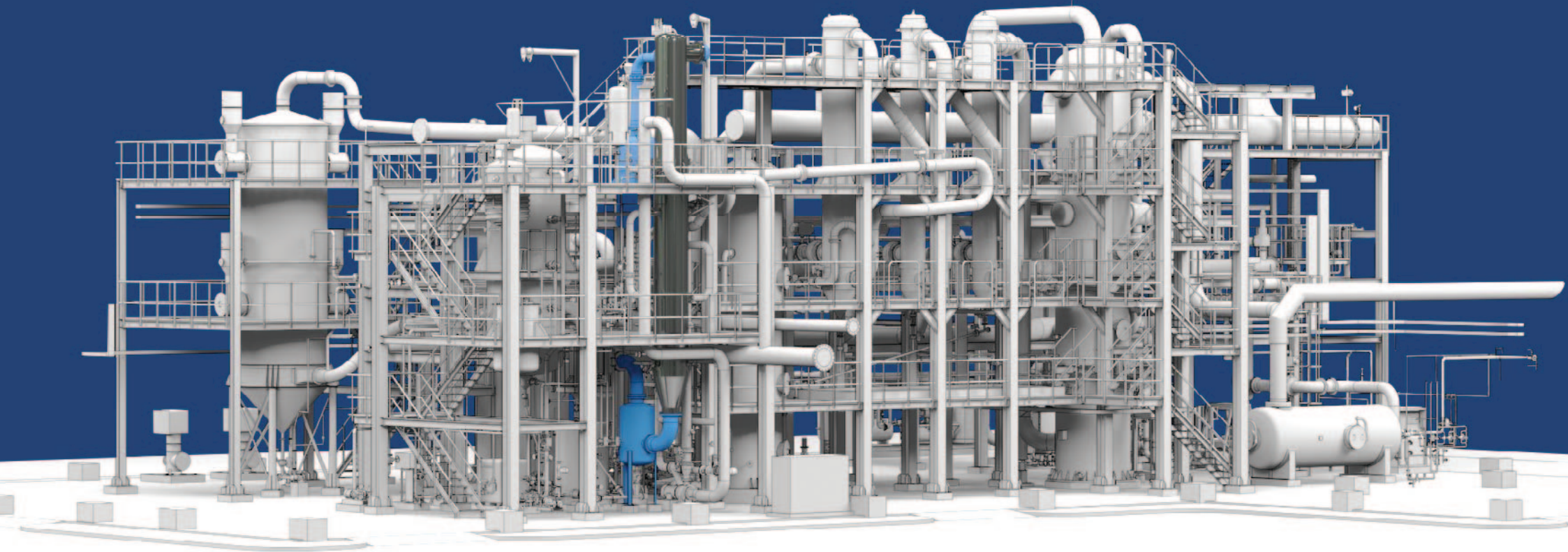

ballestra
SINCE 1960



MAZZONI
SINCE 1946

Gas distribution system

- ✓ The Gas collector design is renewed by computational flow dynamics
- ✓ The new geometry allows a more homogeneous and uniform Gas flow
- ✓ The Gas uniformity permits to control the side reactions, extending the production runs, and producing a constant and high product quality.

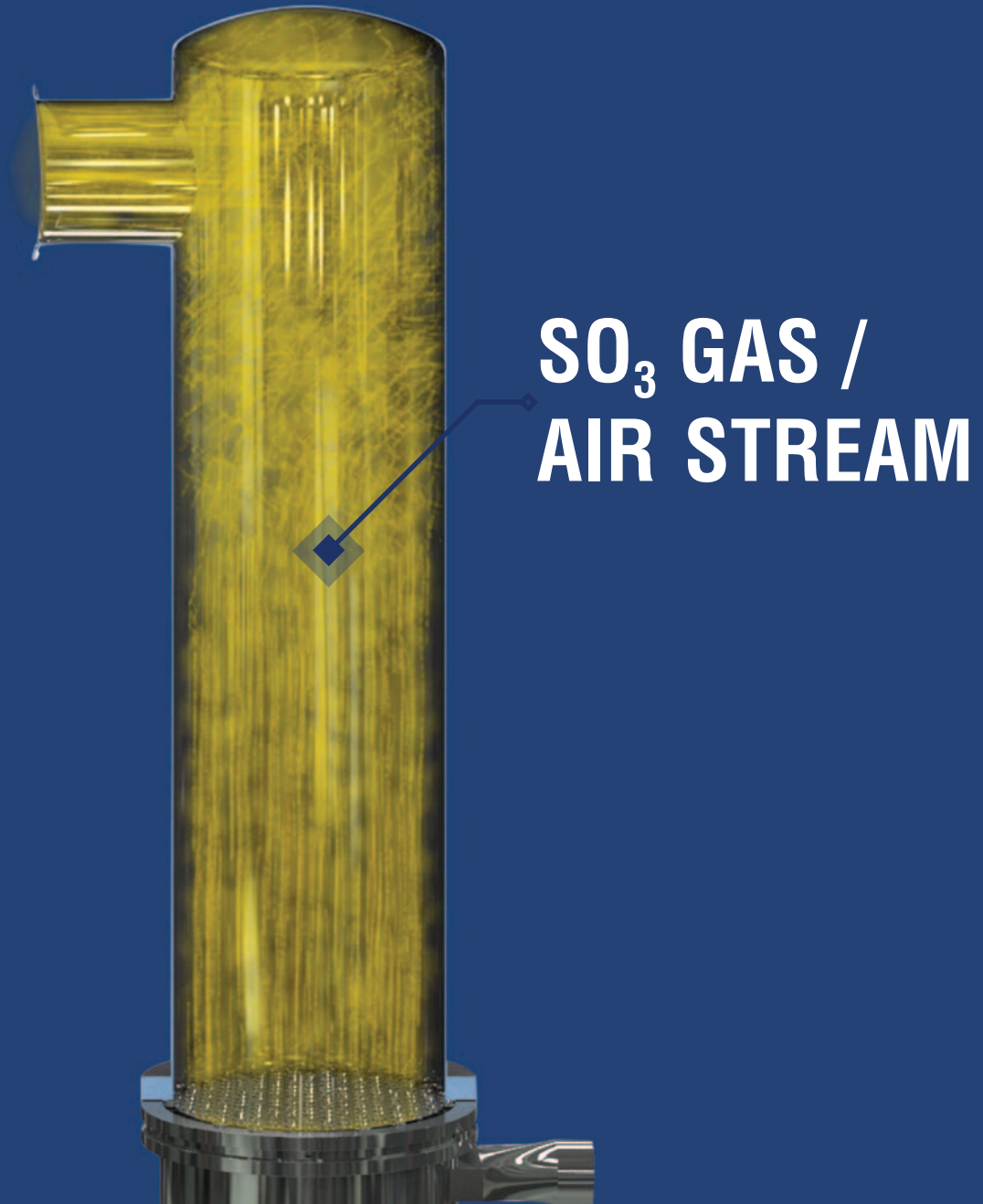

Gas distribution system



**HOMOGENEOUS
GAS FLOW**



**GREATER PROCESS
EFFICIENCY**



**LONGER PRODUCTION
RUNS**

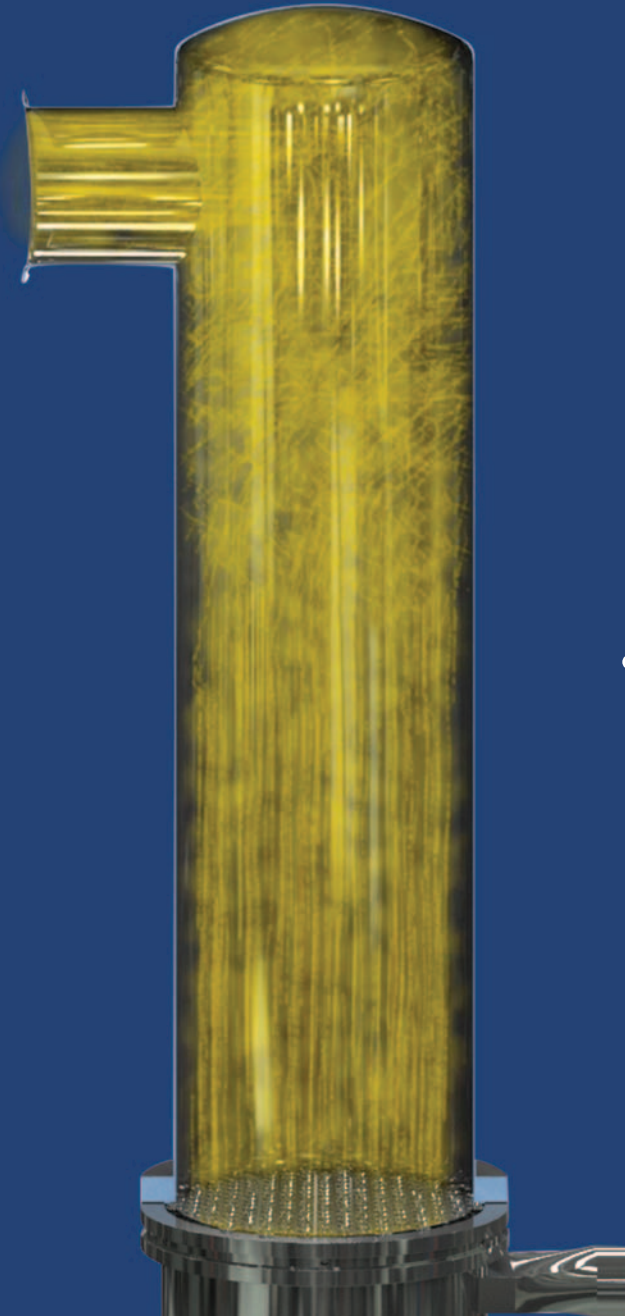

**BETTER
CONTROL**



**REDUCTION OF
SIDE REACTIONS**



**HIGHER PRODUCT
QUALITY**

Reactor tube heads

- ✓ The New Reactor Head is equipped with pre-calibrating nozzle
- ✓ The Liquid Flow is homogenous through all the Reactor Heads thanks to the pre-calibrated nozzle
- ✓ The reactor calibration is not any longer required
- ✓ The calibration is maintained throughout the service life

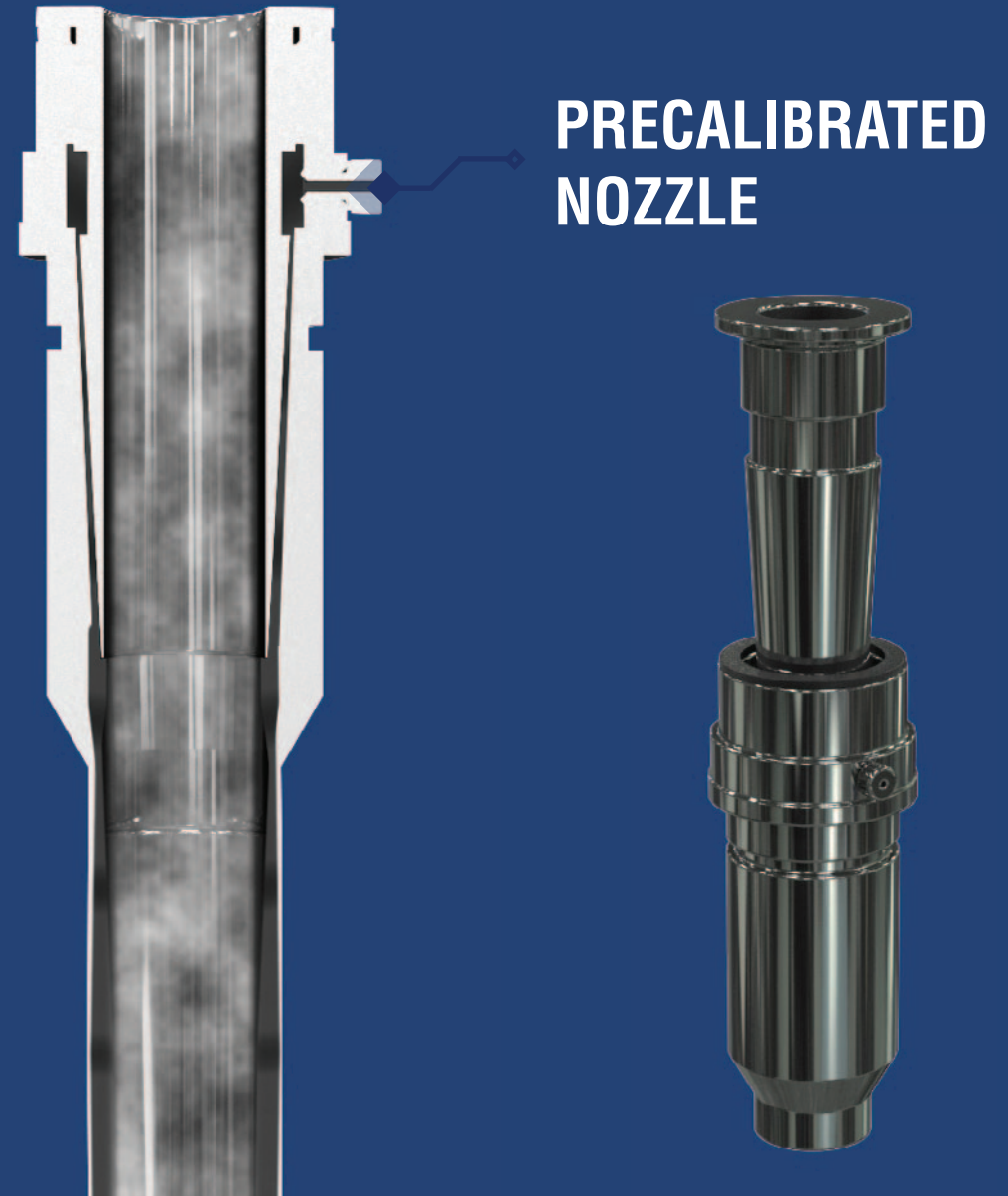

Reactor tube heads

- ✓ The Reactor Head design allows a gentle and uniform gas-liquid contact
- ✓ The reactor head generate a robust and homogeneous liquid film
- ✓ No generation of undesired turbulence

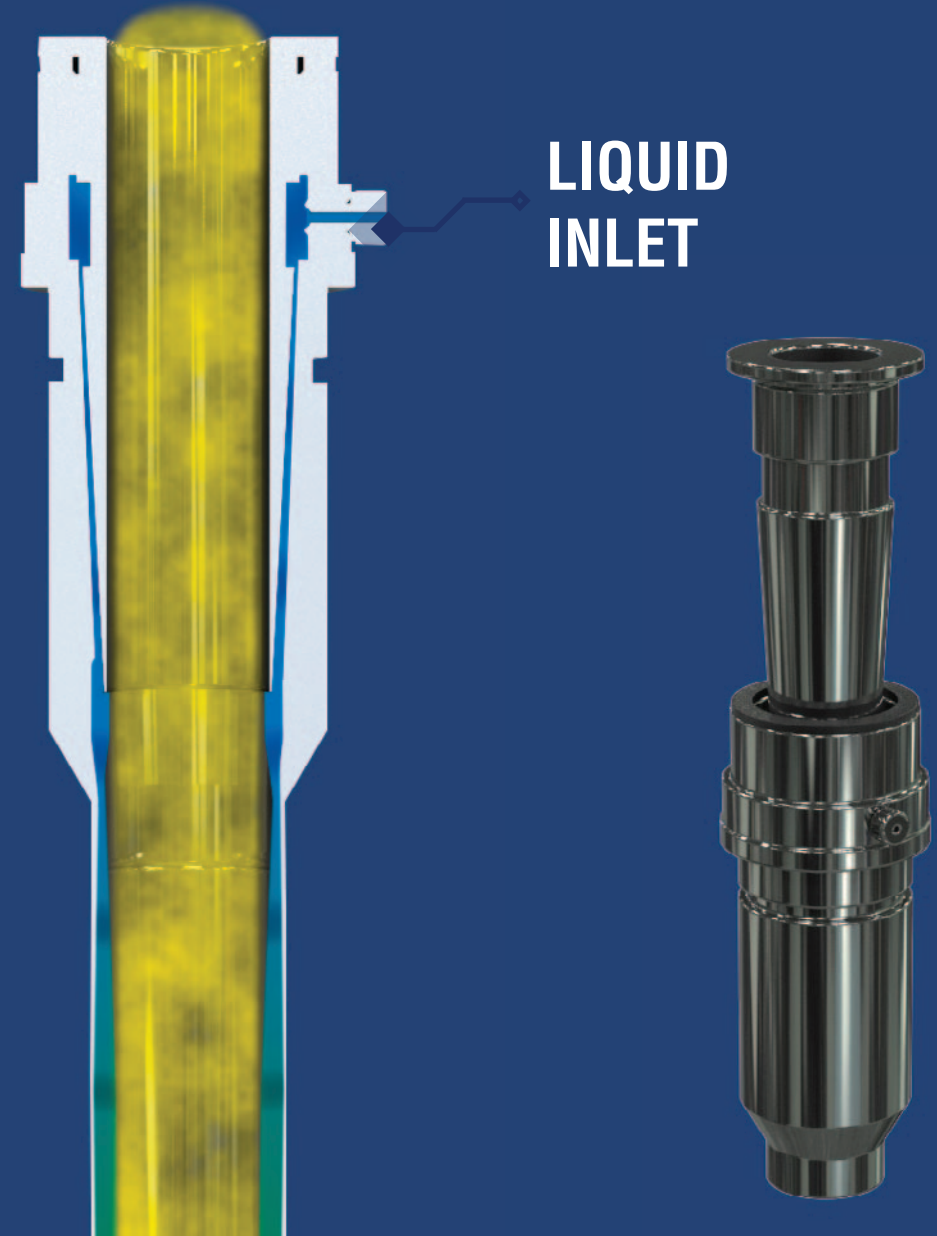

Liquid distribution

✓ Each single head receives by design the same quantity of liquid

✓ The liquid chamber is optimized to obtain a homogeneous and uniform liquid distribution through all the heads

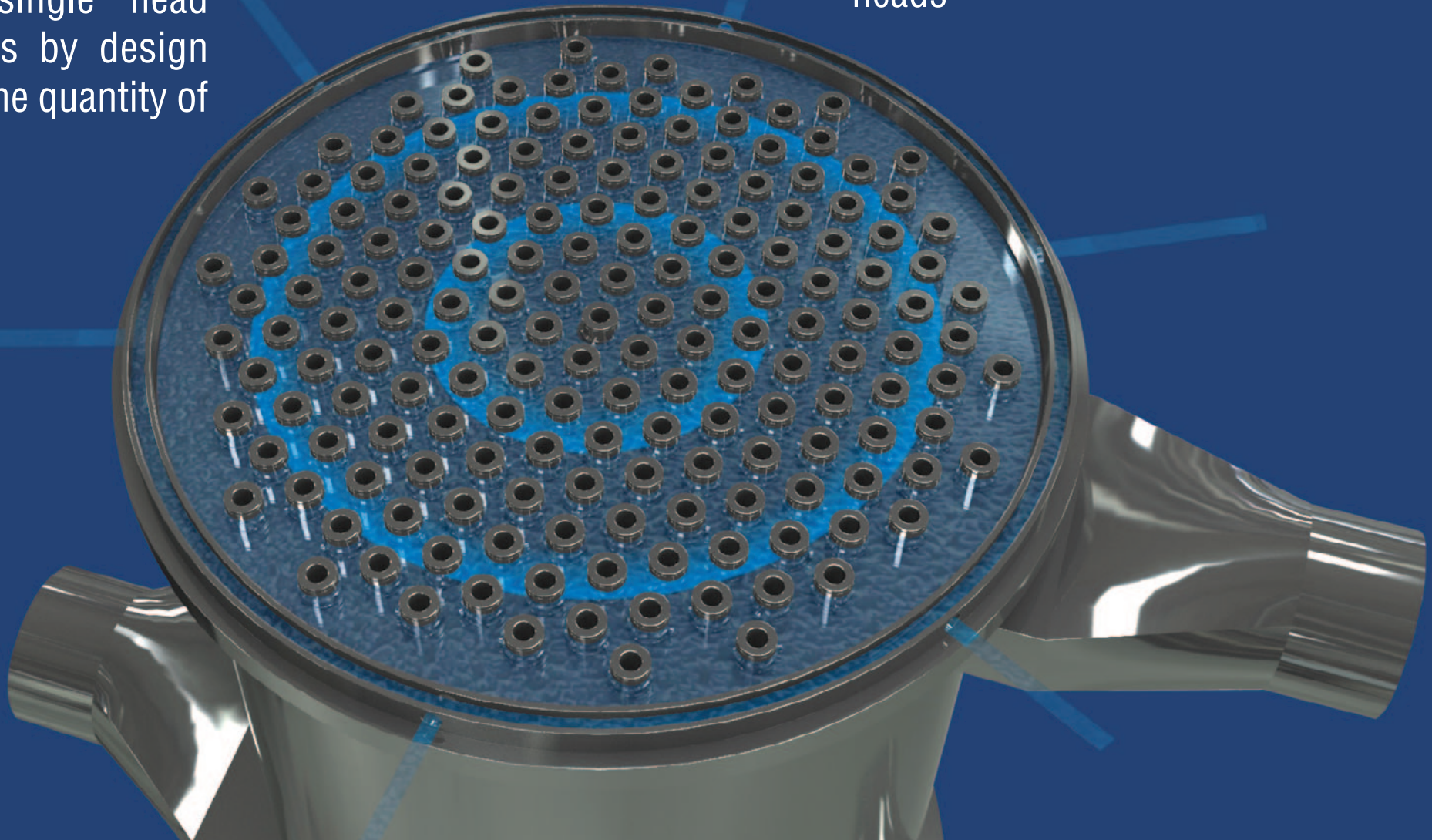

Reactor cooling

- ✓ The top part of the reactor, the most critical one, is optimized to get an efficient cooling.
- ✓ The homogeneous cooling throughout all the pipe permits to avoid hot-spot, avoiding side reactions and deliver the best quality

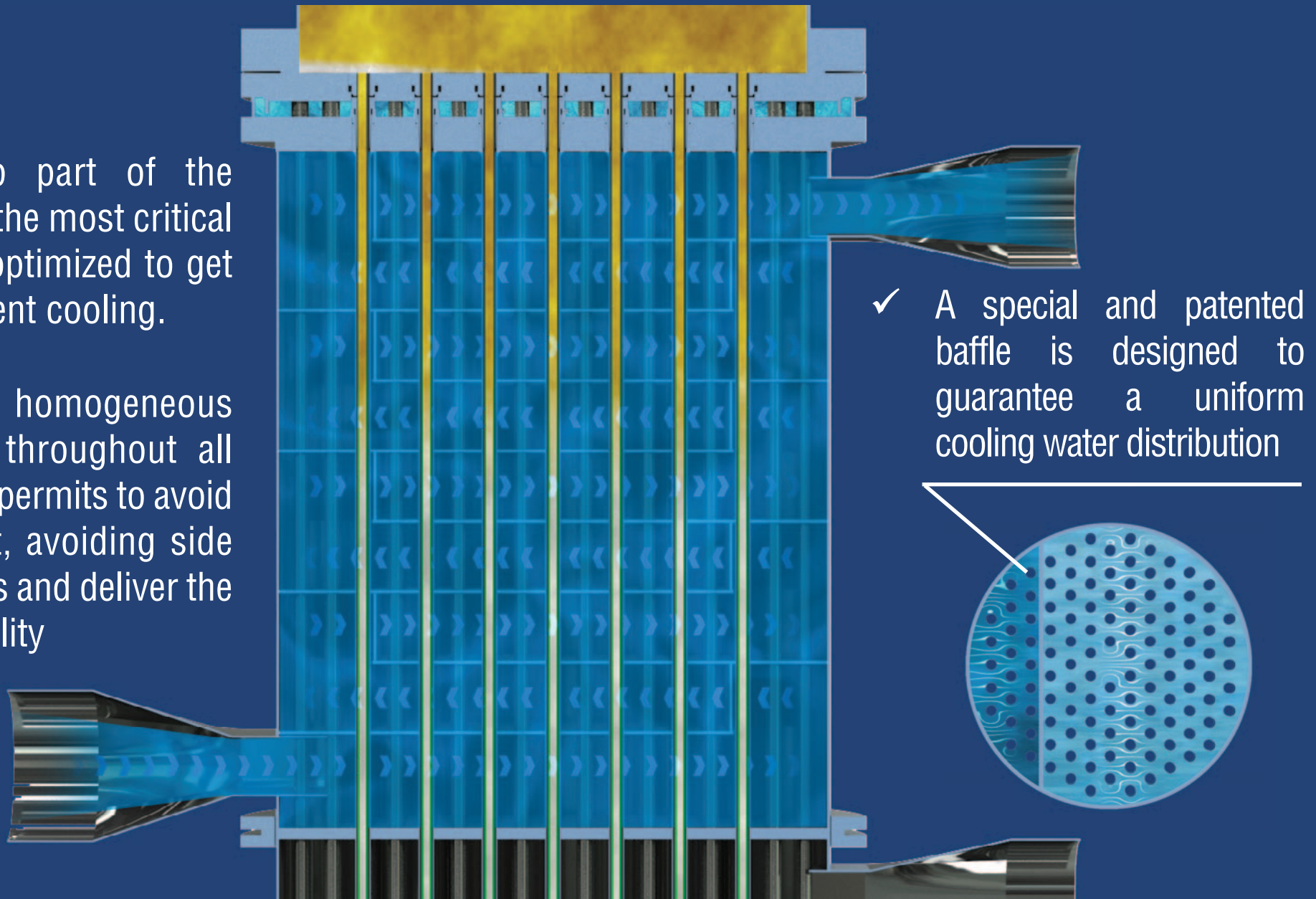

Construction features

EXPANDED
TUBES



MORE ROBUST
CONSTRUCTION



ABSENCE OF
LEAKAGES

Ethoxy-sulphates quality improvement

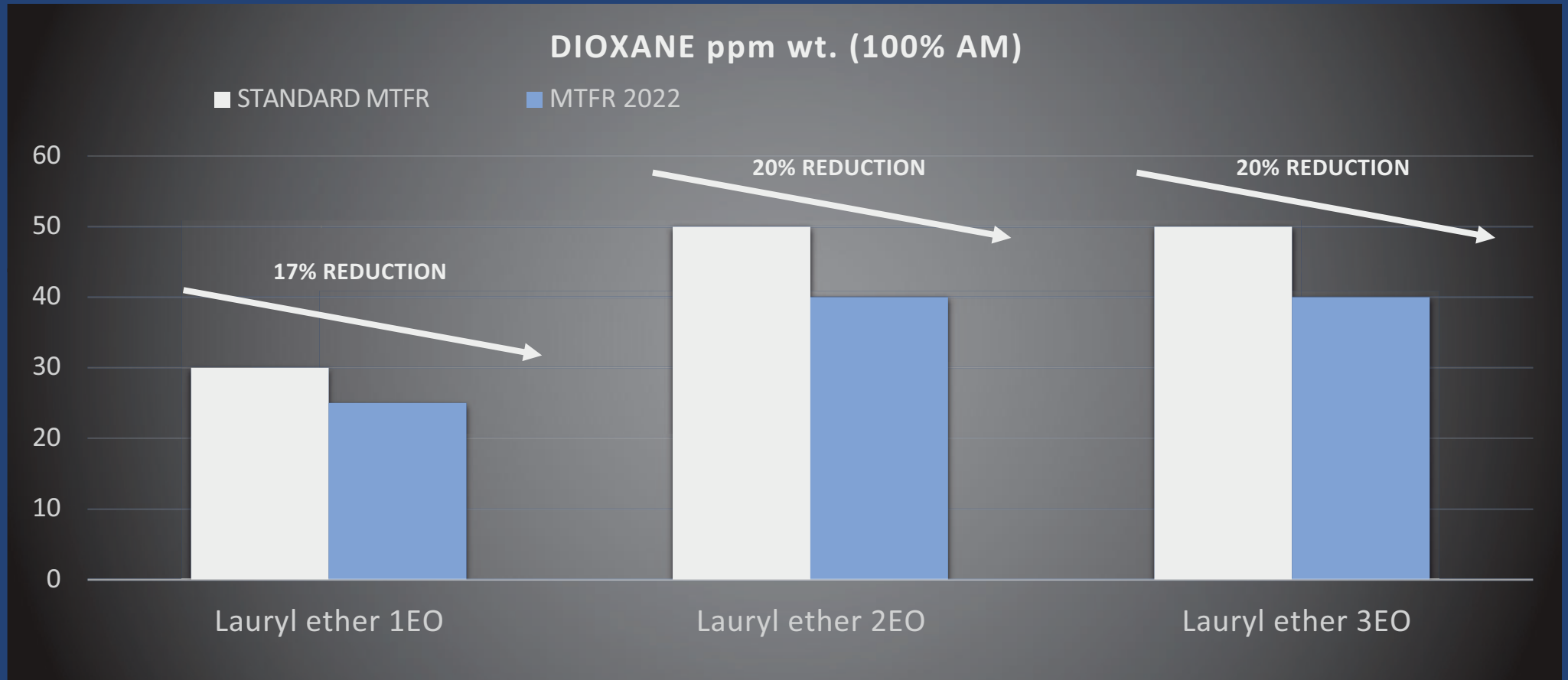

Ethoxy-sulphates quality improvement

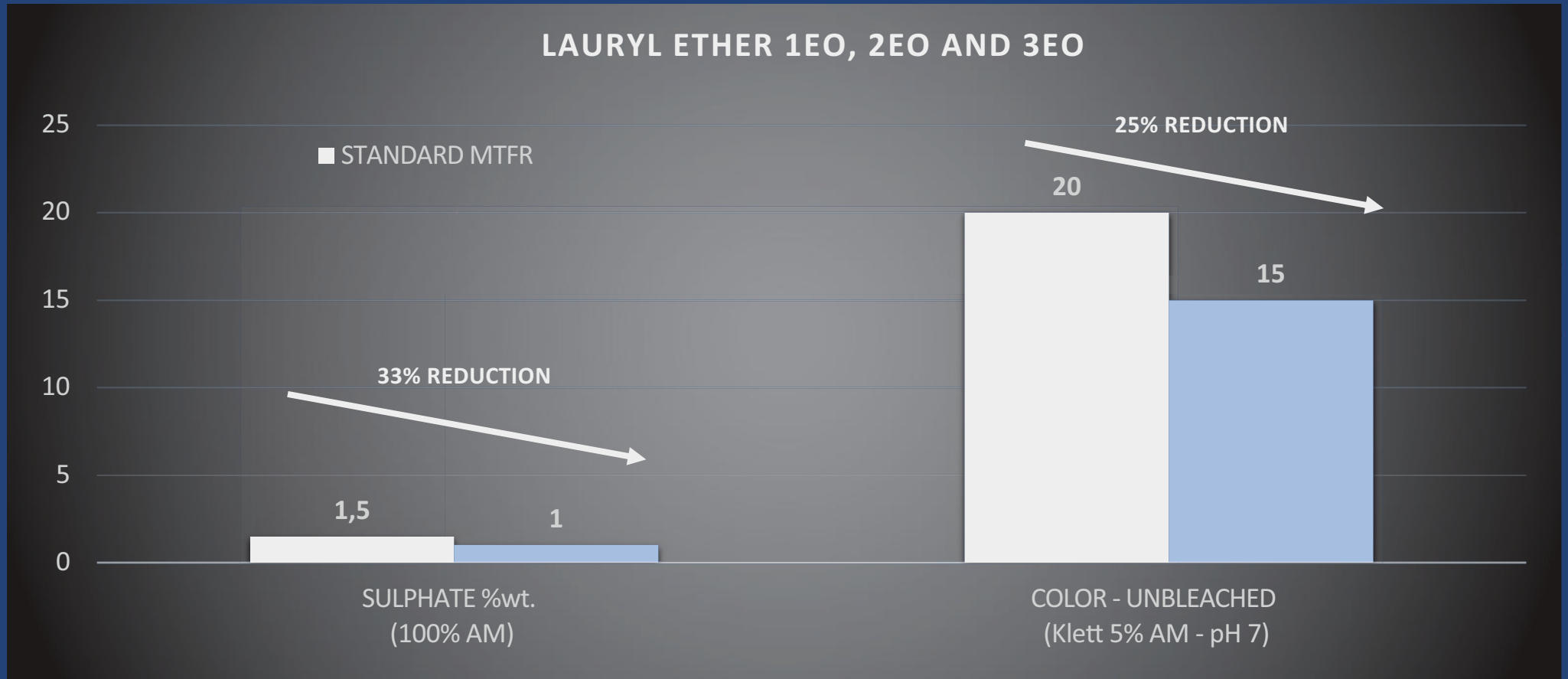

SULPHONEXT Reactor advantages



**HIGH
RELIABILITY**



**FLEXIBILITY
OF USE**



**LOW
EMISSIONS**

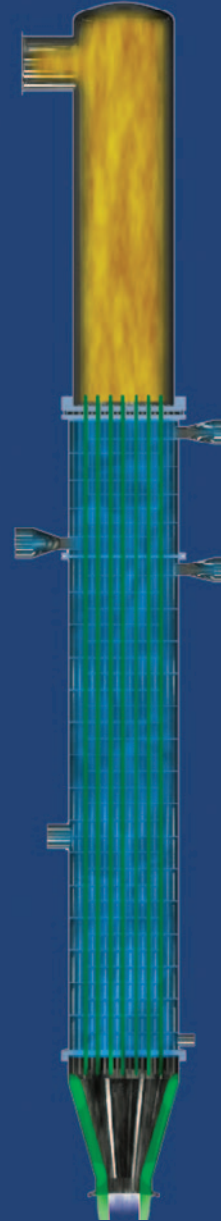

**EASE
OF OPERATION**



**REDUCED
MAINTENANCE**



**INCREASING
OPERATION
RELIABILITY**



North America Agent

Neil A Burns LLC

Freehold, NJ 07728

+1 (732) 688-9585

www.neilaburns.com

neil@neilaburns.com

ballestra

SINCE 1960



MAZZONI
SINCE 1946

Via Piero Portaluppi, 17

20138 Milano - ITALY

Tel +39 0250831

www.ballestra.com

mail@ballestra.com

Corso Sempione 212 Bis

21052 Busto Arsizio - ITALY

Tel +39 0331 356111

www.mazzonilb.it

info@mazzonilb.it